



Siera®
ALWAYS RELIABLE

**SIERA VSP 8720HD 4in1
PTZ CAMERA
USER'S MANUAL**

www.sieraelectronics.com

WARNINGS AND CAUTIONS

WARNING

TO REDUCE THE RISK OF FIRE OR ELECTRIC SHOCK, DO NOT EXPOSE THIS PRODUCT TO RAIN OR MOISTURE. DO NOT INSERT ANY METALLIC OBJECTS THROUGH VENTILATION GRILLS OR OPENINGS ON THE EQUIPMENT.

CAUTION



EXPLANATION OF GRAPHICAL SYMBOLS



The lightning flash with arrowhead symbol, within an equilateral triangle, is intended to alert the user the presence of non-insulated “dangerous voltage” within the product’s enclosure that maybe of sufficient magnitude to constitute a risk of electric shock to different persons.



The exclamation point within an equilateral triangle, is intended to alert the user the presence of important operating and maintenance (servicing) instructions in the literature accompanying this product

PRECAUTIONS:

- Persons without technical qualifications should not attempt to operate this dome device before reading this manual thoroughly.
- Remove any power to the dome before attempting any operations or adjustments inside the dome cover to avoid potential damage to the mechanism.
- Inside the dome cover there are precision optical and electrical devices. Heavy pressure, shock and other sudden adjustments or operations should be avoided. Otherwise, you may cause irreparable damage to the product.
- Please DO NOT remove or disassemble any internal parts of the video camera to avoid normal operation and possibly void the warranty. There are no serviceable parts inside the camera.
- All electrical connections to the dome should be made in strict accordance with the attached labels and wiring instructions in this manual. Failure to do so may damage the dome beyond repair and void the warranty.
- For outdoor installation, especially in high places or poles, it is highly recommended that the proper lightning rod and surge suppressors are installed before the dome is entered into service.
- Please do not use the product under circumstances where the limits exceed the maximum specified temperature, humidity or power supply specifications.

IMPORTANT SAFEGUARDS

1. Read these instructions before attempting installation or operation of dome device
2. Keep these instructions for future reference
3. Heed all warnings and adhere to electrical specifications Follow all instructions
4. Clean only with non-abrasive dry cotton cloth, lint free and approved acrylic cleaners
5. Should the lens of the camera become dirty, use special lens cleaning cloth and solution to properly clean it.
6. Do not block any ventilation openings. Install in accordance with manufacturer's instructions
7. Use only attachments or accessories specified by the manufacturer
8. Verify that the surface you are planning to use for attaching the dome can adequately support the weight of the device and mounting hardware
9. Protect this devices against lightning storms with proper power supplies
10. Refer all servicing to qualified service personnel. Servicing is required when the device has been damaged in any way, when liquid traces are present, or the presence of loose objects is evident or if the device does not function properly, or has received sever impact or has been dropped accidentally.
11. Indoor dome is for indoor use only and not suitable for outdoor or high humidity locations. Do not use this product under circumstances exceeding specified temperature and humidity ratings.
12. Avoid pointing the camera directly to the sun or other extremely bright objects for prolonged period of time avoiding the risk of permanent damages to the imaging sensor.
13. The attached instructions are for use by qualified personnel only. To reduce the risks of electric shock do not perform any servicing other than contained in the operating instructions unless you are qualified to do so.
14. During usage, user should abide by all electrical safety standards and adhere to electrical specifications for the operation of the dome. The control cable for RS485 communications as well as the video signal cables should be isolated from high voltage equipment and or high voltage cables.
15. Use supplied power supply transformer only.

INDEX

1 Product Introduction	6
1.1 Package Contents	6
1.2 Specification	7
1.3 Function Description	8
2 Installation	10
2.1 Coaxial Control	10
2.1.1 AC24V power cable transmission distance and cable requirement.....	10
2.2 Bracket Dimensions.....	10
2.2.1 Wall Mounted Bracket.....	10
2.2.2 Corner Mounted Bracket	11
2.2.3 Pole Mounted Bracket	11
2.2.4 Ceiling Mounted	12
2.3 Installation of Brackets.....	12
2.3.1 Wall Mounted	12
2.3.2 Corner Mounted	14
2.3.3 Pole Mounted	15
2.3.4 Ceiling Mounted	15
2.4 Connection	16
3. Function Instruction.....	17
3.1 Power Up Action	17
3.2 Basic Function.....	17
3.3 Shortcut commands.....	18
3.4 Screen Character Operation.....	18
4 OSD Menu	19
4.1 Menu Index	20
4.2 System Information.....	20
4.3 Dome.....	21
4.3.1 Communication	21
4.3.2 IR Display.....	21
4.3.3 Guard Tours.....	22
4.3.4 A-B Scan	22
4.3.5 Pan Scan.....	23
4.3.6 Park Action	23
4.3.7 Privacy Zone	24
4.3.8 Alarm (Optional)	24

4.3.9 Advanced	25
4.4 Camera	25
4.5 Language	26
4.6 Display	26
4.7 Reset.....	26
5. Auto Temperature Control	27
Appendix I Anti-lightning, Anti-surge	27
Appendix II Clean Transparent Cover	28
Appendix III Common Knowledge on RS-485 Bus.....	28
1. Basic Feature of RS-485bus.....	28
2. Mode of Connection and Terminal Resistance.....	28
Appendix IV Exception Handling.....	29
Copyright Statement	30

=====

* Indicates the functions with default protocol, it might not function by using other protocols

※ Indicates the optional functions, only with certain mode.

1 Product Introduction

1.1 Package Contents

IR Speed dome	1pc
Wall mount bracket	1pc
Power supply	1pc
Screws kits	1pc

1.2 Specification

Speed Dome	Speed Dome
Horizontal Rotation Speed	60°/s
Tilt Rotation Speed	30°/s
Horizontal Rotation Range	360°
Tilt Rotation Range	93°
Auto Flip	Horizontal 180°, Vertical 93°
Auto Control IR LED	PWM
A-B Scan	User programmable
A-B Scan Speed	01-64speed setting available
360° Scan Speed	01-64speed setting available
Dwell Preset	01-60s interval
Preset Points	220
Go to Preset Speed	01-64speed setting available
Guard Tours	3 groups
Guard Points	Max.16 points, dwell time user selectable
Home Pos Time	1-60mins available
PWR on Action	Restore as power up/Pan scan/A-B scan/Park action/Guard tour group 1-3/No action
Communication Protocol	Pelco-D, Pelco-P
Communication	RS485 Bus/ Coaxial
Baud Rate	1200/2400/4800/9600bps (Default is 2400bps)
Privacy Mask	Depend on the zoom module
Alarm	Optional
Operating Temperature	Indoor: 0°~ +40° , Outdoor: -40°~ +60°
Operating Humidity	≤95% Non Condensing
Heater & Blower	Auto temperature control
Power	DC12V
Lightning Protection	transient voltage 6000V
IR Illumination Distance	50-120m(Depend on the model!)
Power Consumption	≤ 25W

1.3 Function Description

Super Communication

Address, baud rate and protocol could be changed from OSD.

Privacy Mask

Depend on the zoom module. This function allows user to set privacy protected area as unviewable in the monitoring scope.

Alarming Set

The dome supports this feature in optional, details please refer to the OSD menu.

IR Detection Time

Time duration switching from Color to B/W or B/W to Color. It can be set through OSD

Focus

The auto focus enables the camera to focus automatically to maintain clear image. User can use manual focus to in special condition.

Under the following conditions camera will not auto focus on the camera target:

- (1) Target is not the center of the screen;
- (2) Attempting to view images that are far and near at the same time;
- (3) Target is strongly lighted object, such as neon lamp, etc.;
- (4) Targets are behind the glass covered with water droplets or dust;
- (5) Targets are moving quickly;
- (6) Monotonous large area targets, such as wall;
- (7) Targets are too dark or faint.

BLC

If a bright backlight is present, the target in the picture may appear dark or as a silhouette, BLC enhance the target in the center of the picture, the dome uses the center of the pictures to adjust the iris. if there is a bright light source outside this area, it will wash out to white, the camera will adjust the iris so that the target in the sensitive area will properly exposed.

Iris Control

Factory default is automatic camera aperture, in mode of which camera senses changes in ambient light through moving and adjust automatically lens aperture to make the brightness of output image stable.

Users can pressing OPEN or CLOSE iris adjusting keys, manually adjust the aperture size to get the required picture brightness.

By controlling the keyboard up, down, left, right or zoom to resume auto iris (auto iris is recommended).

Day/Night Switch

With auto day/night switch function, when the illumination is low the picture will auto switch from day to night mode and when the illumination is high enough the picture will auto switch from night to day mode

Ratio Speed

Intelligent pan and tilt speed is variable depend on the zoom factor. When zooming in, the speed will become slower and when zooming out, the speed will become quicker.

A-B Scan

Dome circularly scan close-up real-time scene according to A-B points at setting speed in both horizontal and vertical directions.

Pan Scan

Dome 360°clockwise continuous scan the display scene at setting speed in horizontal direction under the condition that pitch angle remains the same.

Preset

After the dome camera keeps arbitrary PTZ location, it will automatically move to the defined position when preset is called.

Guard Tours

Dome patrol scans according to certain edited preset order.

Power Off Memory

This feature allows the dome to resume its previous preset or status after power is restored. By default setting, the dome support power up memory, which improves the reliability and avoids repeated settings of the parameter.

Park Action

If users don't operate the dome in set time, it will automatically run preset specific mode (pan scan, A-B scan, park action, cruise, preserve action etc.).

Zero Alignment

There is a point specified as zero point. When the dome is working, the preset point is not accurate because of something caused by the operator. User can make the dome automatically enable the zero alignment by operational order.

Auto Flip

In the manual tracking mode, when a target goes directly beneath the dome, the dome will automatically rotate 180 degree in horizontal direction to maintain continuity tracking. When the dome flips, the camera starts moving upward as long as you hold the joystick in the down position.

2 Installation

2.1 Coaxial Control

The dome supports coaxial control and also supports RS-485 communication signal.

2.1.1 Power cable transmission distance and cable requirement

In general, the power cable has resistance, there are internal losses when transmitting the voltage, the longer of the cable used, the smaller the wire diameter, the worse loss will suffer. In order to avoid losses of cable causing low voltage and keep the dome work properly, when processing wiring please refer to the requirement below:

Cable diameter	0.5mm ² (20#)	1.0mm ² (18#)	1.5mm ² (16#)	2.5mm ² (14#)
Dome distance	11m(37ft)	18m(60ft)	29m(95ft)	46m(152ft)

For example, if a dome is 35 meters away from the power supply, power cable used must be more than 2.5mm², otherwise, the dome may suffer insufficient power supply and could not work properly.

Remark: The dome with DC12V should be less than 3 meters away from power supply.

2.2 Bracket Dimensions

2.2.1 Wall Mounted Bracket

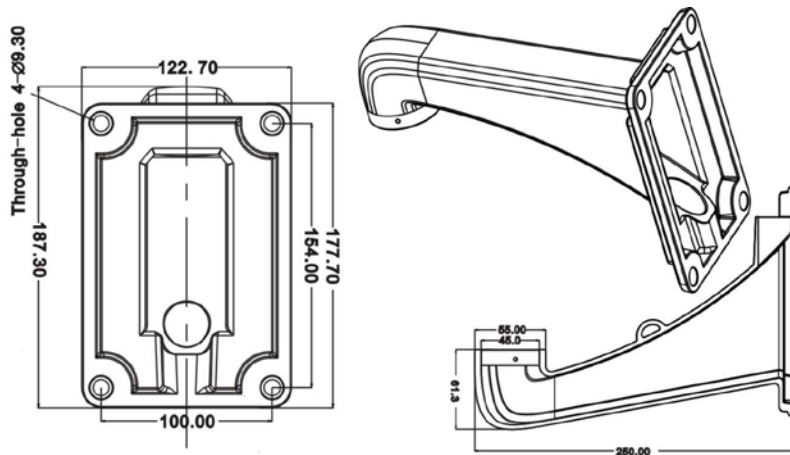

2.2.2 Corner Mounted Bracket

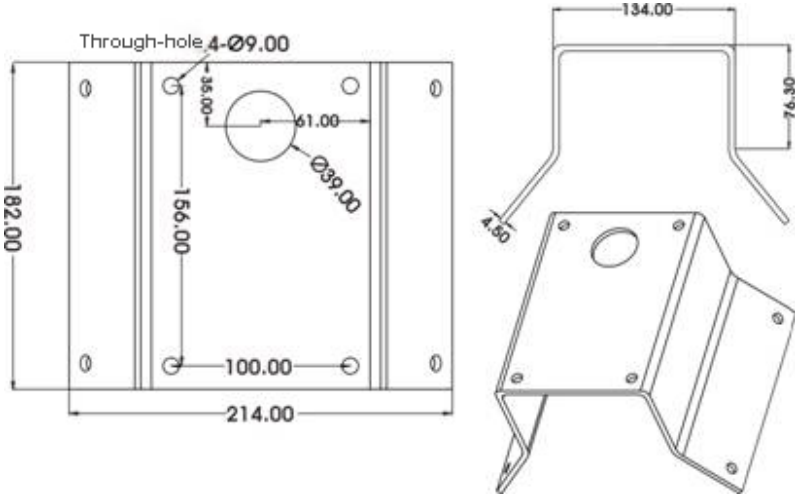

2.2.3 Pole Mounted Bracket

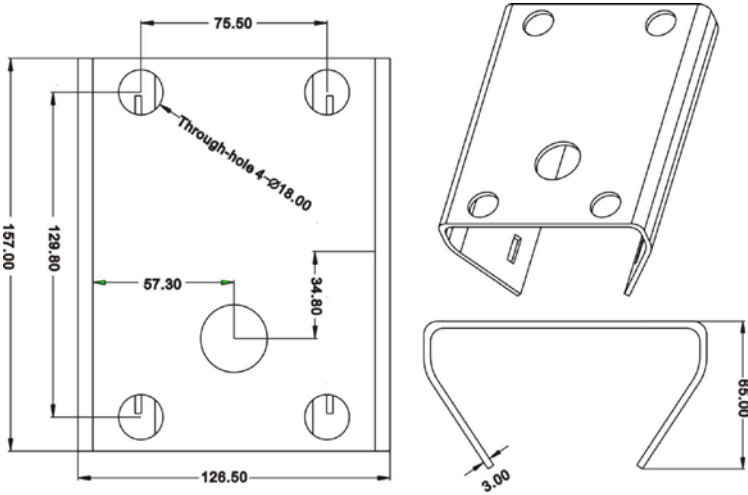

2.2.4 Ceiling Mounted

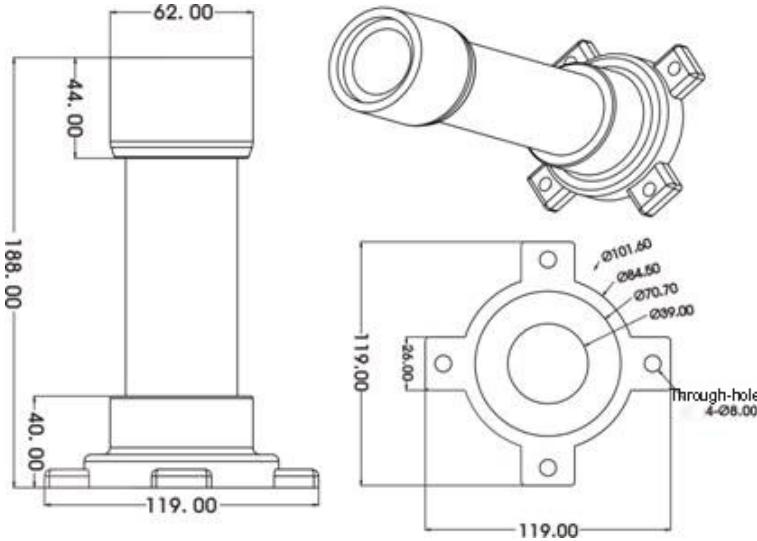

2.3 Installation of Brackets.

2.3.1 Wall Mounted

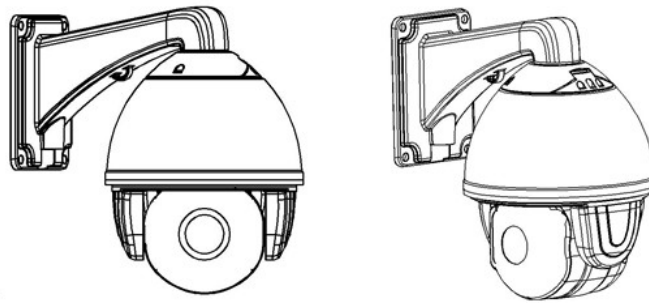

Fig 1

Installation conditions:

Wall mounted dome can be used in the hard wall structure whose thickness should be enough to install expansion bolt in indoor and outdoor environment. The wall can bear at least 4 times the weight of the dome. Install wall hanging bracket:

a. As shown in fig 2, with the installation holes in the underside of the wall hanging bracket as pattern, draw punched locations and punch.

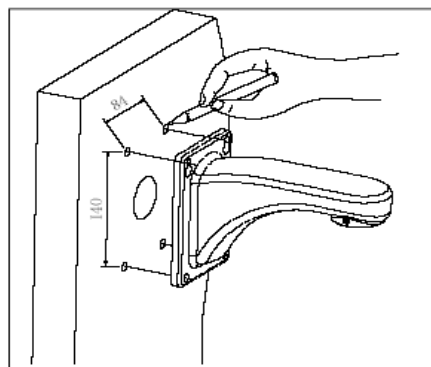

Fig 2

b. As shown in fig 3, fix the wall hanging bracket on the wall with wire and cable through it.

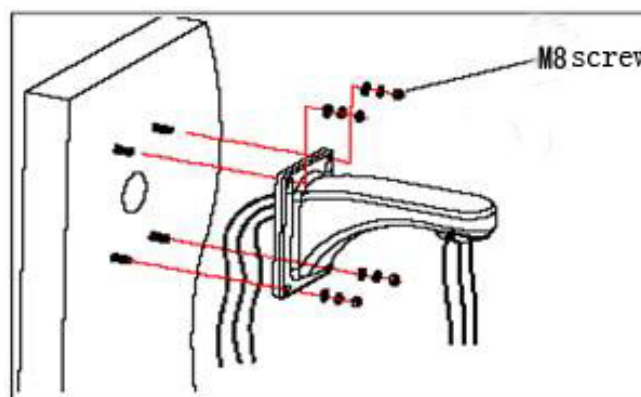

Fig 3

2.3.2 Corner Mounted

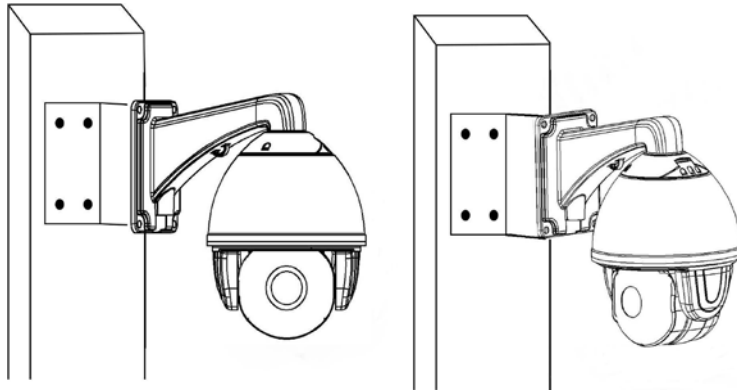

Fig 11

Installation conditions:

Corner mounted dome can be used in the hard wall structure with an angle of 90° whose thickness should be enough to install expansion bolt in indoor and outdoor environment. The wall can bear at least 4 times the weight of the dome. Install corner mounted attachment and wall hanging bracket:

a. As shown in fig 12, with the installation holes in the corner mounted attachment as pattern, draw punched locations on the wall with an angle of 90° and punch to install expansion bolt.

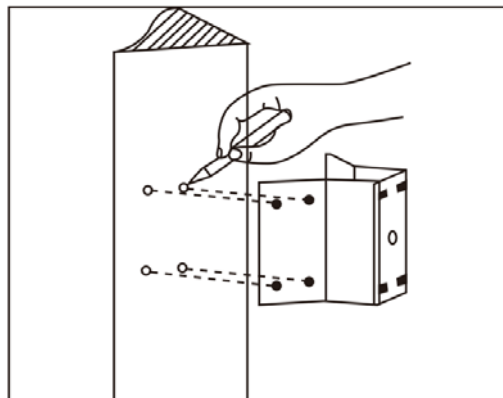

Fig 12

b. As shown in fig 13, use M8 screw nut to fix the base of corner mounted on the wall with all cables through the center holes of the corner mounted, marine glue and bracket. Enough wiring length should be left.

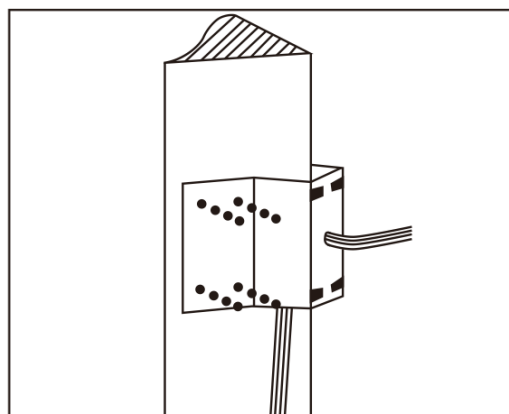

Fig 13

c. As shown in fig 14, fix the wall hanging bracket with all cables power through it on the corner mounted attachment.

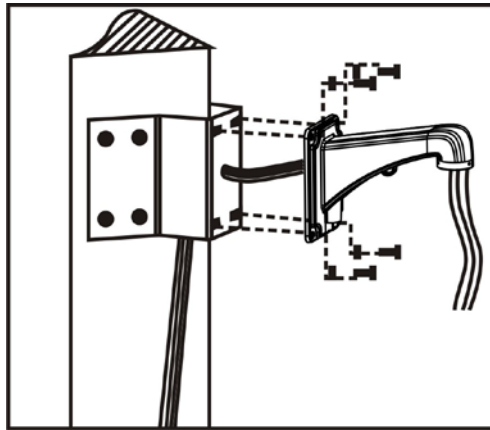

Fig 14

2.3.3 Pole Mounted

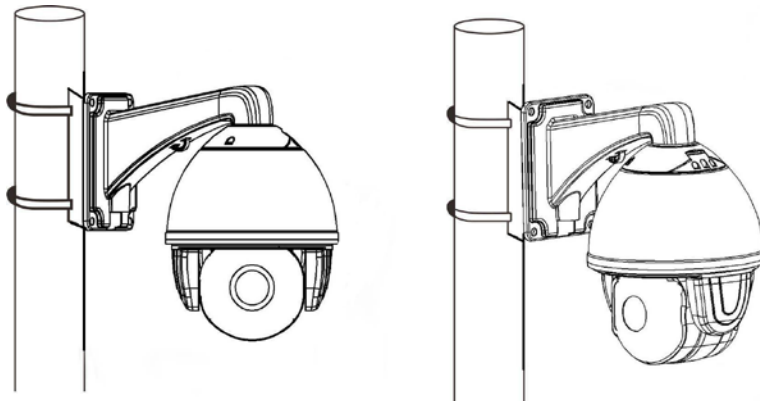

Fig 15

Installation conditions:

Pole mounted dome can be used in the hard pole structure in indoor and outdoor environment whose diameter should match the installation size of stainless hose clamps. Factory default is 6 inches stainless hose clamps (fit ϕ 130-152mm pillar). The pole structure can bear at least 4 times the weight of the dome. Install corner mounted attachment and wall hanging bracket:

a. As shown in fig 16, use the stainless hose clamps to fix the pole mounted attachment with all cable through it on the pole structure.

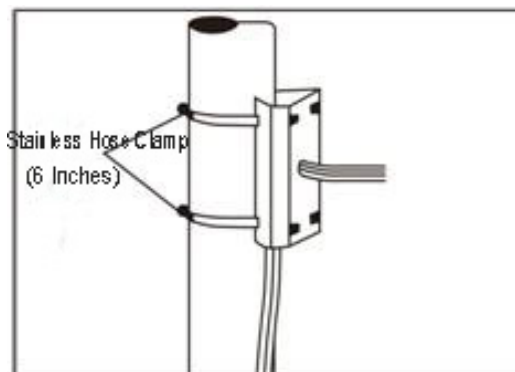

Fig 16

b. As shown in fig 17, fix the wall hanging bracket with all cables through it on the pole mounted attachment.

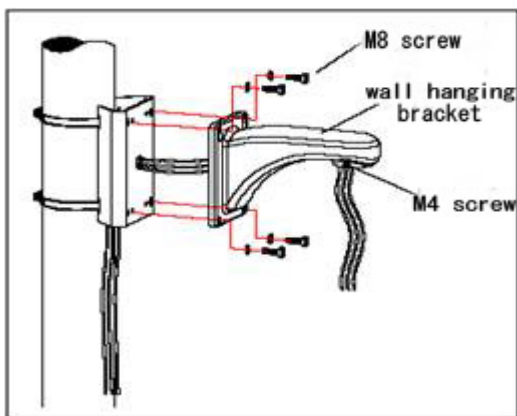
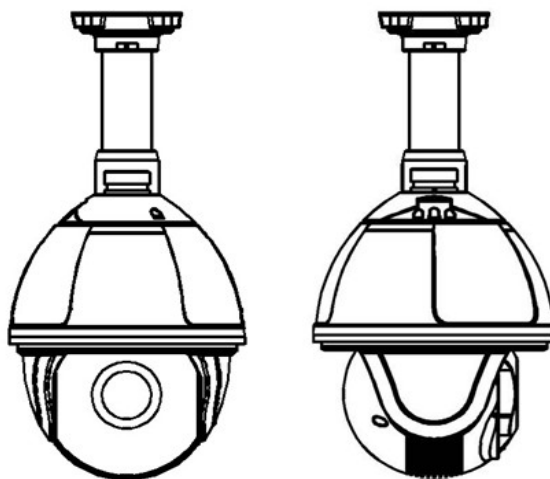

Fig 17

2.3.4 Ceiling Mounted



Fig

Installation conditions:

Ceiling mounted dome with thick pole can be used in the hard ceiling structure whose thickness should be enough to install expansion bolt in indoor and outdoor environment. The ceiling can bear at least 4 times the weight of the dome. Install the base of ceiling and boom:

a. As shown in fig 19, with the installation holes in the base of ceiling as pattern, draw punched locations in the ceiling and punch to install M6 expansion bolt.

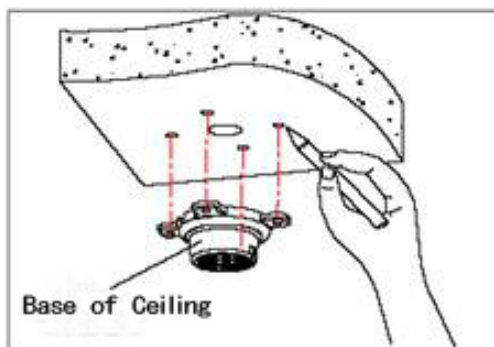

Fig 19

b. As shown in fig 20, at first unscrew the M4 screw at the side of the base of ceiling and split the base of ceiling and boom. Then make the three groups of cables of power, video/control and alarming into the side recessing seal groove of the ceiling connector bottom and through the core hole of the base of ceiling mounted. Fix the base of hang ceiling on the ceiling board.

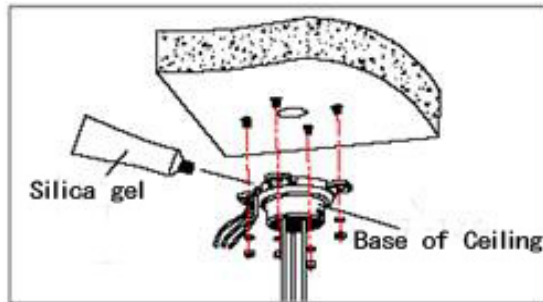

Fig 20

Note: If the dome is used in the outdoor conditions, use the silica gel on the faying surface of the base of hang ceiling and the ceiling board and around the out-holes to be sure water proof

c. As shown in the fig 21, tighten the boom with electrical wire and cable through it on the base of ceiling and screw up the M4 screw.

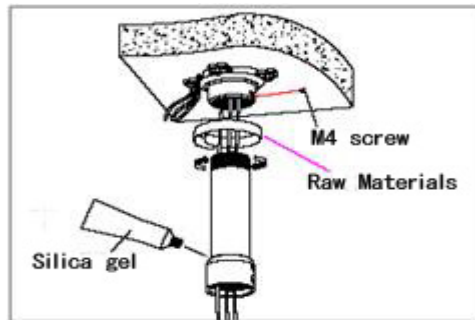

Fig 21

Note: If the dome is used in the outdoor conditions, after using enough raw materials to wrap the thread at the upper end of boom, tighten the boom on the base of ceiling. Use the silica gel around the joint sleeve and connector of the boom to be sure water proof

2.4 Connection

Connection of RS485

Before connecting, please turn off the power and read carefully the instructions of all connected devices.

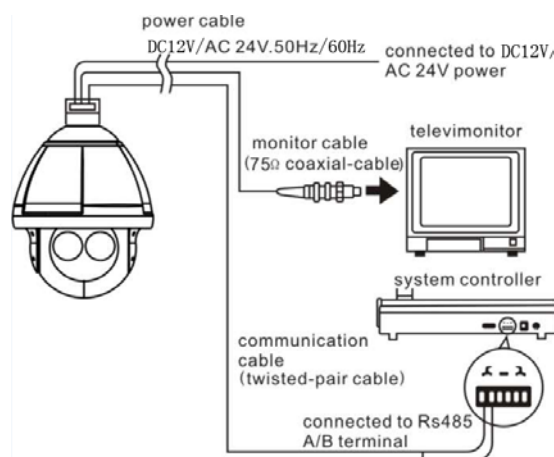

Fig 24

3. Function Instruction

3.1 Power Up Action

<SYSTEM>	
MFG	
PROTOCOL	AUTO
DOME ID	
COMM	
VERSION	
TEMPERATURE	
DETECTING...	

Power Up Self Testing

<SYSTEM>	
MFG	
PROTOCOL	AUTO
DOME ID	
COMM	
VERSION	
TEMPERATURE	
PAN: XXX	TILT: XXX

Pan, Tilt, Camera Self-test Completion

- ✧ Pan action: Pan rotate in certain direction and stop in zero coordinate.
- ✧ Tilt action: Tilt rotate in certain direction and stop in zero coordinate.
- ✧ Lens action: Lens zooming out to be max.
- ✧ From running the action above to power up mode completion, power up self-testing finishes.

3.2 Basic Function

Dome Running

Control joystick or up, down, left and right key in the keyboard.

Zoom

Press ZOOM- button to make the lens farther and minify the scene.

Press ZOOM+ button to make the lens closer and magnify the scene.

Focus

Press FOCUS- button , close shot will become clearer while long shot will become fuzzy.

Press FOCUS+ button , long shot will become clearer while close shot will become fuzzy.

Iris

Press IRIS- to shrink the iris and decrease the image brightness gradually.

Press IRIS+ to enlarge the iris and increase the image brightness gradually.

Preset Point

Setting preset to press buttons “preset” + “number” + “enter”.

Calling preset to press buttons “call” + “number” + “enter”.

Deleting preset to press buttons “clear” + “number” + “enter”.

Remark: Some preset points are occupied by special functions.

3.3 Shortcut commands

Below is list of shortcut commands, user can enable the function by shortcut command easily.

Call PREST	FUNCTION	Call PRESET	FUNCTION
16	OSD on/call twice	86	BLC on
34	Reset	87	BLC off
35	Wiper on	88	Freeze on
36	Wiper off	89	Freeze off
79	Digital zoom on	92	A-B scan
80	Digital zoom off	94	OSD off
81	Auto day/night	95	OSD on
82	Switch to night	96	Guard tour 3
83	Switch to day	97	Guard tour 2
84	Force on far light	98	Guard tour 1
85	Force on near light	99	Pan scan

Remark: Some special functions probably can't be effective because of the limit of protocol when the dome controlled by different devices.

3.4 Screen Character Operation

Call preset 95 to enter the OSD, call preset 94 to exit the OSD.

- ✧ Up or Down: Move the option of the OSD, change the set point.
- ✧ Right: Enter the option, select the item or confirm .
- ✧ Left: Return to main menu or cancel.
- ✧ Angle Display: XXX.XX(pan)/XXX.XX(tilt)
- ✧ IR Display: Display on the lower right corner of the screen.

Remark: 1. Items with“< >” mean they have sub menu.

2. “→”means the cursor selecting some option.

3. “※” means editing the content of some option selected.

4. When entering the setting page in menu, it is useless to call preset 94 to exit the menu directly. Such as the sub-menu <SET> in menu <GUARD TOUR SET>.

4 OSD Menu

4.1 Menu Index

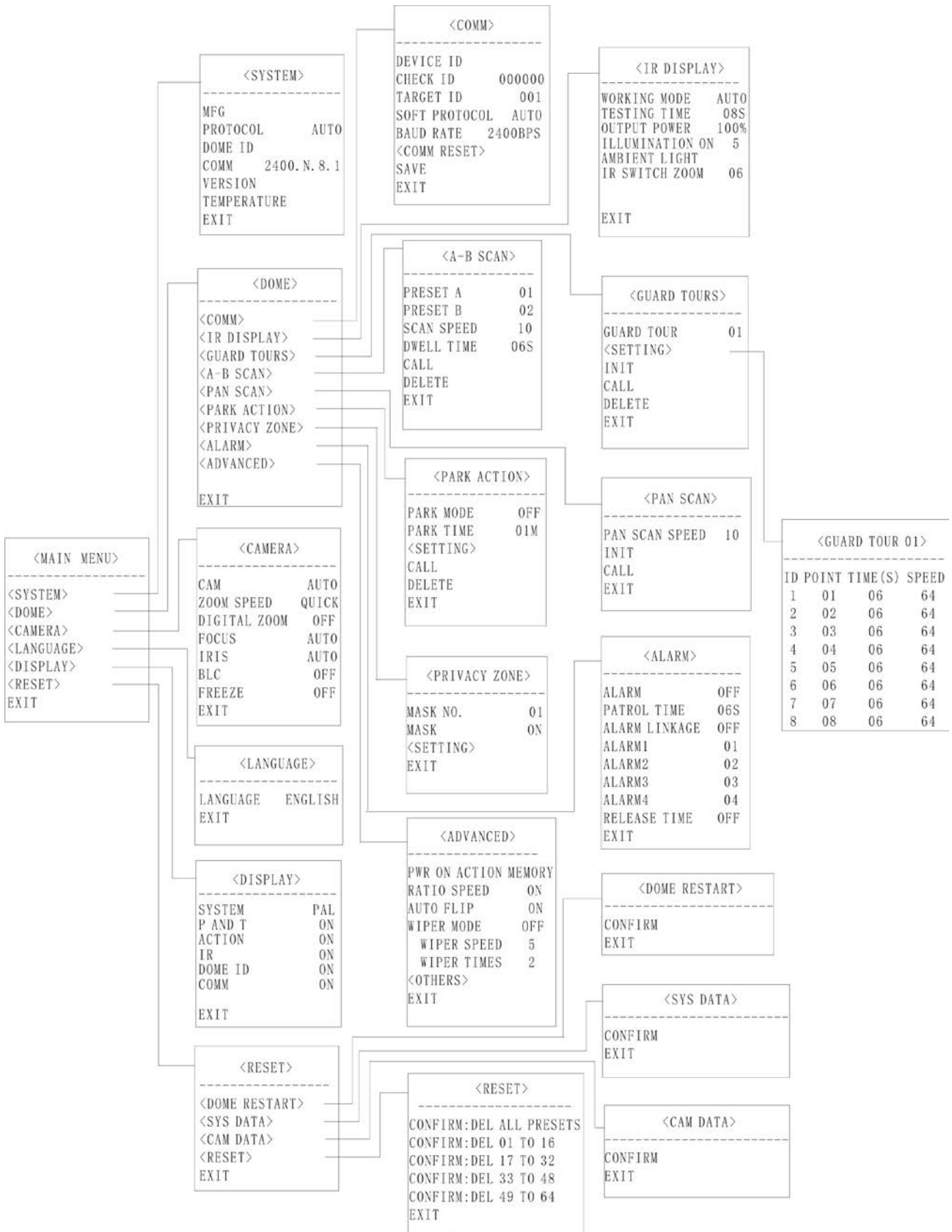

4.2 System Information

<MAIN MENU>	

<SYSTEM>	
<DOME>	
<CAMERA>	
<LANGUAGE>	
<DISPLAY>	
<RESET>	
EXIT	

Get into the Menu

Screen

<SYSTEM>	

MFG	
PROTOCOL	AUTO
DOME ID	001
COMM	2400.N.8.1
VERSION	
TEMPERATURE	
EXIT	

MFG: Max 15 characters displayed on the screen.

PROTOCOL: Display the protocol of the dome

DOME ID: Display the dome address

COMM Form: Baud rate. Check bit. Data bit. Start bit

VERSION: Version will update along with the product upgrading

TEMPERATURE: Display the temperature of the camera, it changes along with the temperature of the camera, the data is unchangeable by manual.

Remark: Protocol, ID

and COMM all can be set in menu <COMM>.

4.3 Dome

<DOME>	

<COMM>	
<IR DISPLAY>	
<GUARD TOURS>	
<A-B SCAN>	
<PAN SCAN>	
<PARK ACTION>	
<PRIVACY ZONE>	
<ALARM>	
<ADVANCED>	
EXIT	

4.3.1 Communication

<COMM>		<COMM RESET>	
DEVICE ID		RESET TO DIAL THE CODE	
CHECK ID	000000	YES	EXIT
TARGET ID	001		
SOFT PROTOCOL	AUTO		
BAUD RATE	2400BPS		
<COMM RESET>			
SAVE			
EXIT			

DEVICE ID: It is sole and auto generated by system.

CHECK ID: To change the TARGET ID, please input the CHECK ID exactly same as the DEVICE ID displays on the screen.

TARGET ID: Target ID is available from 001 to 250 and used to distinguish several domes of same ID.

SOFT PROTOCOL: Soft protocol is auto, Pelco-D and Pelco-P available

BAUD RATE: 1200BPS, 2400BPS, 4800BPS, 9600BPS available

<COMM RESET>: As shown in fig 4,3,1,2, choose “ YES” ,the dome will save the setting automatically and restart

SAVE: After saving, the dome will reboot. Communication setting is enable.

4.3.2 IR Display

<IR DISPLAY>	
WORKING MODE	AUTO
TESTING TIME	08S
OUTPUT POWER	100%
ILLUMINATION ON	3
AMBIENT LIGHT	
IR SWITCH ZOOM	06
EXIT	

WORKING MODE: IR Working mode has auto, black/white, color selectable. Default is auto.

TESTING TIME: On IR auto working mode and the programmed time, the IR will execute programmed action accordingly, eg. Switch from day to night or from night to day. The detection time is from 2s to 15s selectable.

OUTPUT POWER: Output power has 40%,60%,80%,100% for selection!

ILLUMINATION ON: Illumination on is 1 to15 grade selectable and default is 3. On the auto

IR working mode, if the illumination on level is less than the ambient light, the picture will change to color, the IR illumination will turn off automatically. If the illumination on level is more than the ambient light, the picture will change to black, the IR illumination will turn on automatically.

AMBIENT LIGHT: Ambient light is a system data. User can not change it manually. It changes according to the environment all the time. The data will refresh every time when user enter the OSD. It is from 0 to 50 grades.

IR SWITCH ZOOM: When zoom value reaches to the demanded setting, the IR LEDs with auto switch from near illumination to far illumination, zoom value option from 01-10

4.3.3 Guard Tours

<GUARD TOURS>	
GUARD TOUR	01
<SETTING>	
INIT	
RUNNING	
DELETE	
EXIT	

<GUARD TOUR 01>			
ID	POINT	TIME(S)	SPEED
1	01	06	64
2	02	06	64
3	03	06	64
4	04	06	64
5	05	06	64
6	06	06	64
7	07	06	64
8	08	06	64

GUARD TOUR: Total 3 guard tours selectable: 01, 02, 03.

SETTING: Each guard tour includes max 16 presets. The number of the preset is from 0-64, but 0 is not valid. Dwell time is 1 to 60s selectable. Speed is 1 to 64 grades selectable.

INIT: After initial, preset point, dwell time and speed will resume to default.

RUNNING: Running the present guard tour.

DELETE: Delete the guard tour set. After deleted, the present preset points in the guard tours all display as 0. While the exact preset point information doesn't be deleted. So, it is convenient for user to select the preset point needing to be guarded tour.

4.3.4 A-B Scan

<A-B SCAN>	
PRESET A	01
PRESET B	02
SCAN SPEED	20
DWELL TIME	06S
RUNNING	
DELETE	
EXIT	

A-B SCAN	
RUNNING...	
LEFT KEY TO EXIT	
PAN: XXX	TILT: XX

PRESET A: On A-B scan, A point can be preset from 0 to 64.

PRESET B: On A-B scan, B point can be preset from 0 to 64.

SCAN SPEED: A-B scan speed is 1 to 64 grades selectable.

DWELL TIME: Dwell time between A to B is 2s to 60s selectable.

RUNNING: Running the A-B scan. Check Fig. 4.3.4.2.

DELETE: After deleted, the preset points of A and B display as 0. While the exact preset point information doesn't be deleted. So, it is convenient for user to select the preset point needing to be scanned. Speed and dwell time will reset as default setting.

4.3.5 Pan Scan

<PAN SCAN>	
PAN SCAN SPEED	20
INIT	
RUNNING	
EXIT	

PAN SCAN	
RUNNING...	
LEFT KEY TO EXIT	
PAN: XXX	TILT: XX

PAN SCAN SPEED: Pan scan speed is 1 to 64 grades selectable.

INIT: Reset the scan speed and tilt degree as default setting.

RUNNING: Running the scan speed and tilt degree set.

4.3.6 Park Action

<PARK ACTION>	
PARK MODE	OFF
PARK TIME	01M
<SETTING>	
RUNNING	
DELETE	
EXIT	

<PARK ACTION>	
PRESET 1: SAVE	
PRESET 2: BACK	

PARK MODE: Park mode includes OFF, Park action, A-B scan, Pan scan, guard tour 01, guard tour 02, guard tour 03 and Preserve action.

When park mode is OFF status, the dome doesn't run park mode.

(A-B When park mode is PRESERVE ACTION status, it records previous action order scan, Pan scan, Guard tour 01, Guard tour 02, Guard tour 03).

Example: Running A-B scan at first, when the action stops unexpectedly, it enters the park mode to continue to run A-B scan.

PARK TIME: Park time is 01~60 Mins selectable.

SETTING: After entering the OSD menu, as 4.3.6.2, move to the desired position and save the settings.

RUNNING: Running the park action, if there is no setting, system will remind that "Please set park action".

DELETE: Delete the settings.

4.3.7 Privacy Zone

<PRIVACY ZONE>	<PRIVACY ZONE>	<PRIVACY ZONE>
MASK NO. 01 MASK OFF <SETTING>	PRESET 1: SAVE	PRIVACY PROPOSED TO OPEN
EXIT		

MASK NO.: Mask No. depends on the number of the module supported. The selective range of Sony is from 1 to 24.

MASK: Mask has on and off selectable.

SETTING: Set the specific parameter of present mask NO. And call preset 1 to save the settings.

Direction operation—Modify the coordinate of dome

Zoom operation—Modify the size of scenery

Iris operation—Modify the size of privacy zone

Remark: The mask size is better more than double the target size. If needing to modify mask NO.02, set it again. If needing to stop it, set mask to OFF status.

If the module doesn't support privacy mask, the screen will display the interface as Fig. 4.3.7.3.

4.3.8 Alarm (Optional)

<ALARM>	
ALARM	OFF
PATROL TIME	06S
ALARM LINKAGE	OFF
ALARM 1	01
ALARM 2	02
ALARM 3	03
ALARM 4	04
RELEASE TIME	OFF
EXIT	

ALARM: Alarm has OFF and ON selectable.

PATROL TIME: Patrol time is 2~60s selectable.

ALARM LINKAGE: Alarm linkage has OFF and ON selectable.

ALARM 1: To run alarm 1, presets 1-64 are available.

ALARM 2: To run alarm 2, presets 1-64 are available.

ALARM 3: To run alarm 3, presets 1-64 are available.

ALARM 4: To run alarm 4, presets 1-64 are available.

RELEASE TIME: Alarming release time, 2-60s selectable, the default is OFF.

4.3.9 Advanced

<ADVANCED>	
PWR ON ACTION	MEMORY
RATIO SPEED	ON
AUTO FLIP	ON
WIPER MODE	OFF
WIPER SPEED	5
WIPER TIMES	2
<OTHERS>	
EXIT	

PWR ON ACTION: Power on action can be set as Memory, A-B scan, Pan scan, Park action, Guard tour 01, Guard tour 02, Guard tour 03 and No action.

RATIO SPEED: Ratio speed can be set as ON or OFF status.

AUTO FLIP: Auto flip can be set as ON or OFF status.

WIPER MODE: Wiper mode can be set as ON or OFF status.

WIPER SPEED: Wiper speed 1-5 level adjustable.

WIPER TIMES: Wiper times 1-5 times adjustable.

<OTHERS>: Set other options.

4.4 Camera

<CAMERA>	
CAM	AUTO
ZOOM SPEED	QUICK
DIGITAL ZOOM	OFF
FOCUS	AUTO
IRIS	AUTO
BLC	OFF
FREEZE	OFF
EXIT	

CAM: Display the information of module supported by this dome.

ZOOM SPEED: Zoom speed is quick and slow selectable.

DIGITAL ZOOM: Digital zoom is on/off selectable.

FOCUS: Focus is auto and manual selectable

IRIS: Iris is auto and manual selectable

BLC: BLC is ON and OFF selectable

FREEZE: Video freeze is ON and OFF selectable

Remark: Only if those functions are available on the present module, the user can use them.

4.5 Language

<LANGUAGE>	
LANGUAGE	ENGLISH
EXIT	

LANGUAGE: Default Language is English.

4.6 Display

<DISPLAY>	
SYSTEM	PAL
P AND T	ON
ACTION	ON
IR	ON
DOME ID	ON
COMM	ON
EXIT	

SYSTEML: Video system includes NTSC and PAL. N means NTSC and P means PAL.

P AND T: On screen, it displays the pan and tilt degree, user can enable or disable it.

ACTION: On the screen, it displays the current action, such as A-B scan, Call preset, Save preset, Call park action, Pan scan etc. User can enable or disable it

IR: IR is ON and OFF selectable.

DOME ID: At the top left corner of screen, it displays the dome ID. User can enable or disable it.

COMM: At the top left corner of screen, it displays the dome communication information. User can enable or disable it.

4.7 Reset

<RESET>
<DOME RESTART>
<SYS DATA>
<CAM DATA>
<PRESET>
EXIT

<DOME RESTART>
CONFIRM: Save data, dome restart
EXIT

<SYS DATA>
CONFIRM: Factory default
EXIT

<CAM DATA>
CONFIRM: Factory default
EXIT

<PRESET>
CONFIRM: DEL ALL PRESETS CONFIRM 1: DEL 01 TO 16 CONFIRM 2: DEL 17 TO 32 CONFIRM 3: DEL 33 TO 48 CONFIRM 4: DEL 49 TO 64

CONFIRM: Delete the presets information saved by the dome.

5. Auto Temperature Control

This product has built-in fan and heater, which accordingly cool or heat through temperature sensitive circuit inside the dome.

Appendix I Anti-lightning, Anti-surge

This product is extremely air discharge and lightning protection with TVS tube technology, which can effectively prevent the transient lightning below voltage 6000V, surge and damages caused by other types of pulse signals.

However, necessary protective measures should be made in the premise of ensuring electrical safety for outdoor installation according to the actual situation:

- Signal transmission line must be at least 50 meters far away from the high-voltage equipment or high voltage cable.
- Try to choose outdoor wiring laid down along the roof line.
- Way of sealed steel pipe buried wiring is used in the area which opened, and steel pipe units grounded in one point. Overhead wiring is absolutely prohibited.
- In the strong thunderstorms area or areas with high induced voltage (such as high voltage substations), measure of installation of additional high-power lightning protection equipment and lightning rod must be taken.
- Lightning protection and grounding of outdoor devices and lines must take the lightning-protection requirements of buildings into consideration, and comply with the related national standards and industry standards.
- System must be equipotential grounding. Grounding device must meet dual requirements of anti-interference and electrical safety, and should not be shorted or mixed with the adjacent lines in the strong power grid. When system is independently grounded, grounding impedance should be less than 4Ω , and cross-sectional area of grounding conductor must be not less than 25mm^2 .

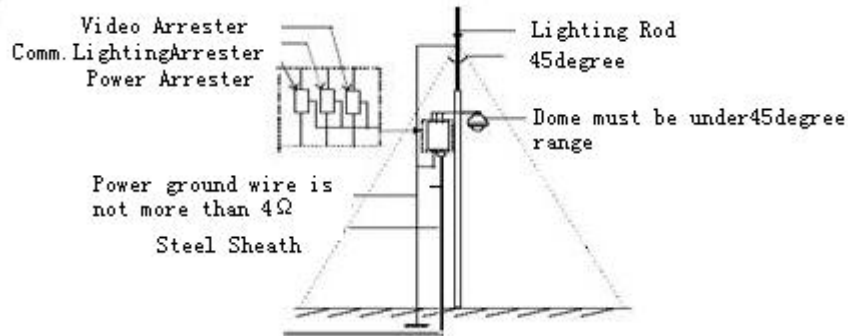

Fig 1

Appendix II Clean Transparent Cover

In order to assure a clear image of dome, the under cover of dome should be cleaned regularly.

- Be careful when cleaning and hold the outer ring of under cover by hands to avoid directly touching with it. Because the acid sweat of finger membrane may corrode the surface coating of undercover. Hard tool scratching the under cover may lead to blurring the images of dome so that affecting image quality.
- Please use a soft enough dry cloth or other alternatives to wipe internal and external surface.
- If dirt is serious, user can use a mild detergent. Any senior furniture cleaning products can be used to clean the under cover.

Appendix III Common Knowledge on RS-485 Bus

1. Basic Feature of RS-485bus

According to industry bus standard of RS-485, RS-485 bus is half-duplex communication bus with the characteristic impedance of 120Ω , whose maximum load capacity is 32 payloads (including the master device and the controlled device).

2. Mode of Connection and Terminal Resistance

2.1 Industry standard of RS485 bus requires that connection in a daisy chain should be used between the devices with 120Ω terminal resistances connected at the both ends.

As shown in fig. 26 and fig. 27 is simplified connection, but the distance of part "D" shall not beyond 7 meters.

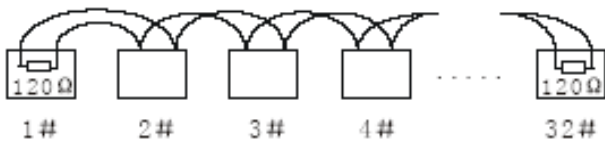

Fig 2

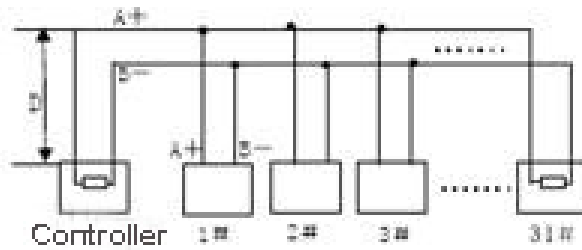

Fig 3

2.2 120Ω terminal resistance is connected as shown in fig 2.

120Ω terminal resistance is available in the circuit board and the connection is shown as following:

When needing to connect 120Ω resistance, toggle the 8th bit of DIP switch SW2 to "ON" .

This way the 120Ω resistance is connected to the circuit.

Appendix IV Exception Handling

Issue	Possible Reason	Solution
After power is applied, there is no motion (self-test) and no video image.	Cable harness is improperly connected	Verify that the orientation of the connector input
	Input power voltage is too low	Verify the voltage of the input power
	Power supply is not work	Change a new power supply
Self-test is normal, but cannot control dome	Wrong communication settings	Set the correct protocol, baud rate and address of dome device
	Improper connection of control cable (polarity)	Verify the polarity of the RS485 connection as per the instruction manual
Noise after self-testing	Mechanical obstruction	Verify and correct it
	Camera module is not installed correct	Correct
	Low power	Change the correct power supply
Image is not stable	Low power	Check the power supply or make sure the power input is DC 12V
	Video cable is improperly contact	Verify the contact of the video cable
Image is blurring	Camera is on manual focus	Change to auto focus
	The lens is dusted	Clean the lens
Control to the dome is not smooth	Power is too low	Change the DC 12V Power supply
	Communication distance is too long	Make sure the distance is in the allowed range
	RS485 cable is not properly contact	Make the RS485 is properly contact
	Too many domes connected	Make sure the connected dome is in the allowed quantity

